

MNHL 20 PAM - MOTORIDUTTORE P.A.M.

MNHL 20 PAM - ARRANGED GEARED MOTORS

MNHL 20 PAM - GETRIEBE ZUM I.E.C. MOTORANBAU

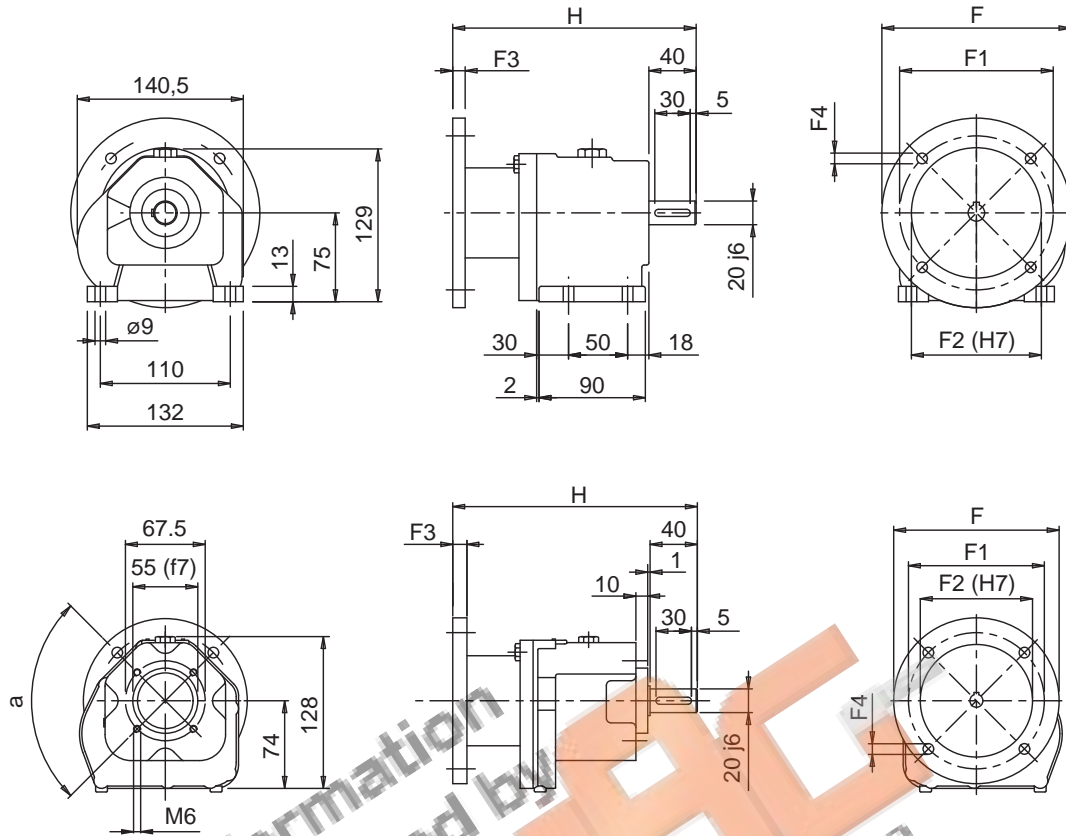

Nota: Disponibile anche con albero uscita  $\varnothing$  16 j6 e 19 j6 mm.

Note: Even available with 16 j6 and 19 j6 mm shaft .

Bemerkung: Verfügbar auch mit 16 j6 und 19 j6 mm welle.

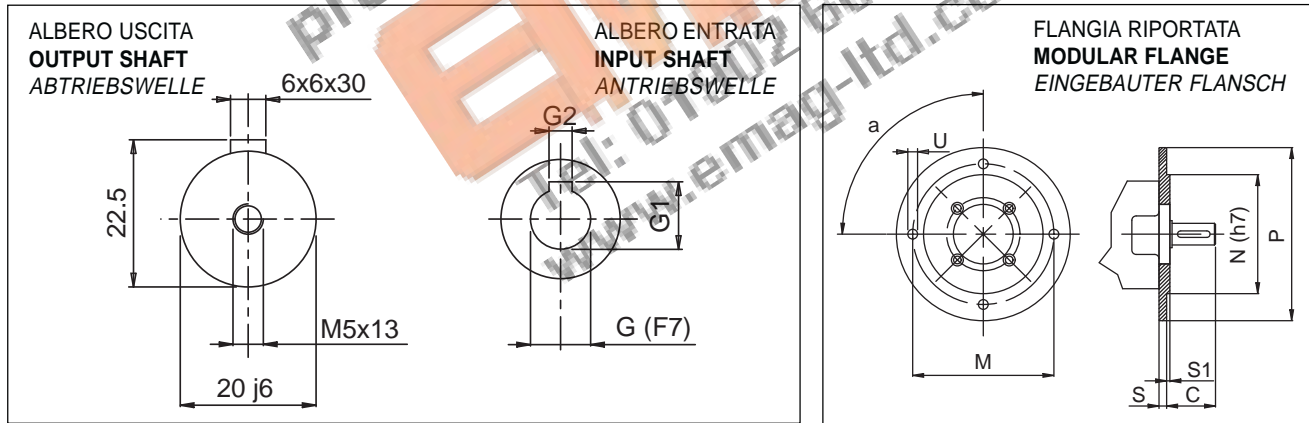

20/2	G	G1	G2	F	F1	F2	F3	F4	H
/2....56 B5 /2F....56 B5	9	10,4	3	120	100	80	8	7	208
/2....63 B5 /2F....63 B5	11	12,5	4	140	115	95	12	9	207
/2....71 B5 /2F....71 B5	14	16	5	160	130	110	10,5	9	206
/2....80 B5 /2F....80 B5	19	21,5	6	200	165	130	10,5	11	206

P = 120							
N	C	M	P	$\alpha$	S	S1	U
80	40	100	120	90°	9	3	7

P = 140							
N	C	M	P	$\alpha$	S	S1	U
95	40	115	140	90°	9	3	9

P = 160							
N	C	M	P	$\alpha$	S	S1	U
110	40	130	160	90°	9	3	9