

MNHL 70 PAM - MOTORIDUTTORE P.A.M.

MNHL 70 PAM - ARRANGED GEARED MOTORS

MNHL 70 PAM - GETRIEBE ZUM I.E.C. MOTORANBAU

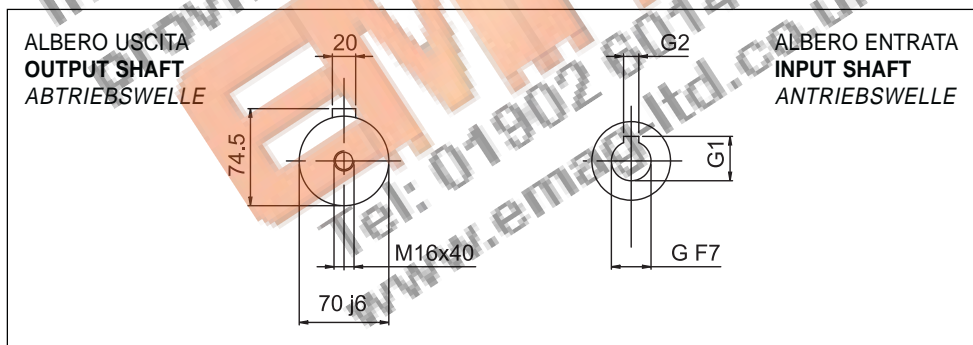
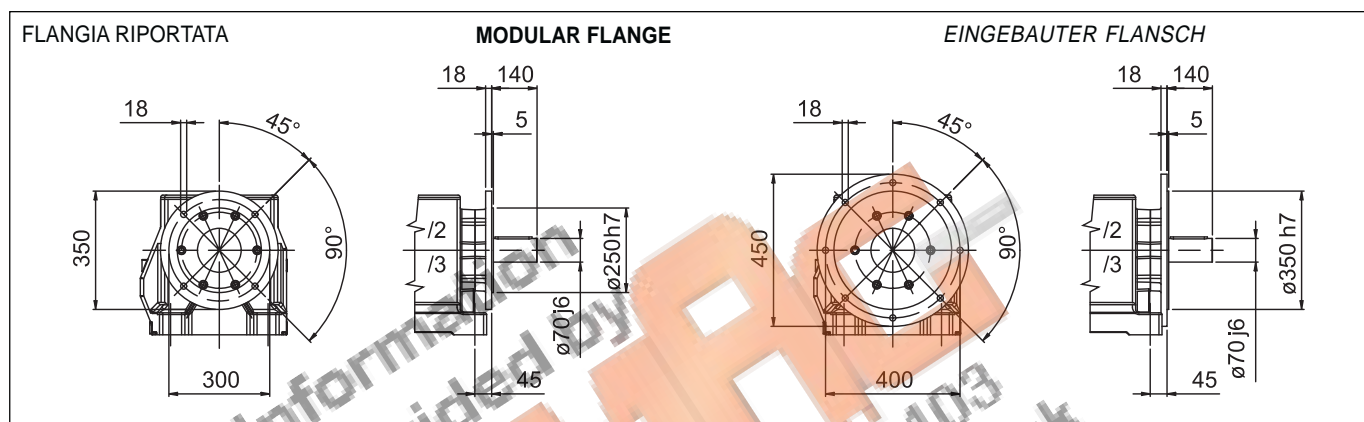
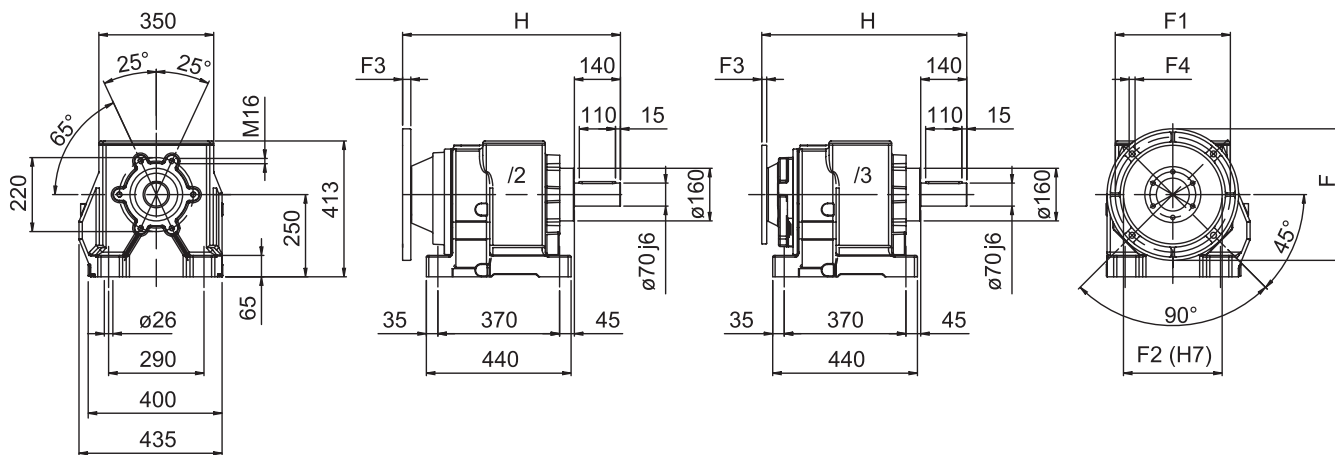

70/2 - 70/3	G	G1	G2	F	F1	F2	F3	F4	H
/2 ... 132 B5	38	41,3	10	300	265	230	25	M12	658
/2F ... 132 B5									
/2 ... 160 B5	42	45,3	12	350	300	250	25	17	658
/2F ... 160 B5									
/2 ... 180 B5	48	51,8	14	350	300	250	25	17	658
/2F ... 180 B5									
/2 ... 200 B5	55	59,3	16	400	350	300	25	18	658
/2F ... 200 B5									
/2 ... 225 B5	60	64,4	18	450	400	350	25	18	658
/2F ... 225 B5									
/3 ... 90 B5	24	27,3	8	200	165	130	15	11,5	609
/3F ... 90 B5									
/3 ... 100-112 B5	28	31,3	8	250	215	180	15	14	612
/3F ... 100-112 B5									
/3 ... 132 B5	38	41,3	10	300	265	230	15	14	612
/3F ... 132 B5									
/3 ... 160 B5	42	45,3	12	350	300	250	19	14	642
/3F ... 160 B5									