

FLANGIA RIPORTATA

MODULAR FLANGE

EINGEBAUTER FLANSCH

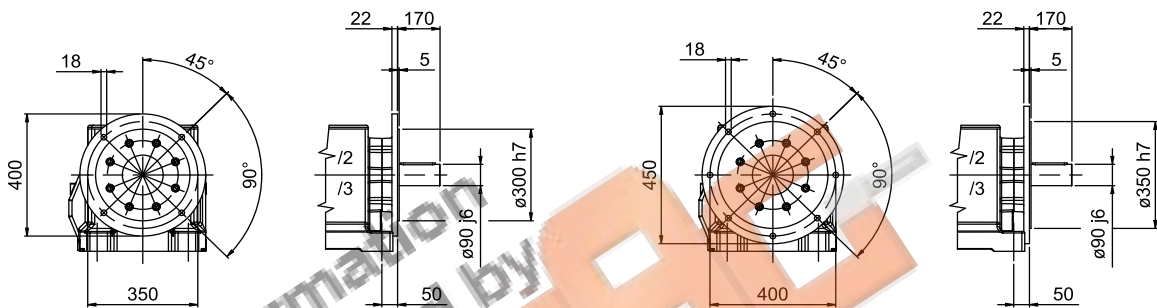

ALBERO USCITA  
OUTPUT SHAFT  
ABTRIEBSWELLE

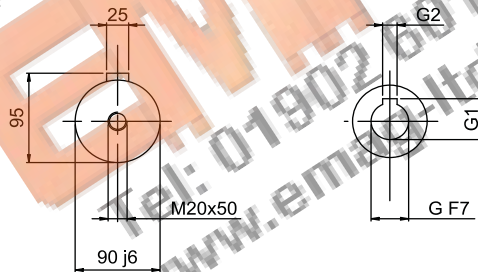

ALBERO ENTRATA  
INPUT SHAFT  
ANTRIEBSWELLE

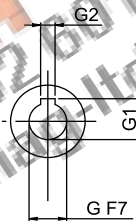

	G	G1	G2	F	F1	F2	F3	F4	H
/2 ... 132 B5	38	41,3	10	300	265	230	25	M12	728
/2F ... 132 B5									
/2 ... 160 B5	42	45,3	12	350	300	250	25	17	728
/2F ... 160 B5									
/2 ... 180 B5	48	51,8	14	350	300	250	25	17	728
/2F ... 180 B5									
/2 ... 200 B5	55	59,3	16	400	350	300	25	18	728
/2F ... 200 B5									
/2 ... 225 B5	60	64,4	18	450	400	350	25	18	775
/2F ... 225 B5									
/2 ... 250 B5	65	69,4	18	550	500	450	25	19*	775
/2F ... 250 B5									
3 ... 100-112 B5	28	31,3	8	250	215	180	25	M12	730
/3F ... 100-112 B5									
3 ... 132 B5	38	41,3	10	300	265	230	25	M12	730
/3F ... 132 B5									
/3 ... 160 B5	42	45,3	12	350	300	250	25	17	730
/3F ... 160 B5									
/3 ... 180 B5	48	51,8	14	350	300	250	25	17	730
/3F ... 180 B5									

\* N°8 FORI A 45°

\* 8 HOLES AT 45 DEGREES

\* 8 LOECHER AUF 45 GRADEN