



E510

Compact Vector Control Drive



TAIWAN
EXCELLENCE
2012

PRODUCT FEATURES



FEATURES AND BENEFITS

Features		Benefit
Capability	32 bit RISC Processor with an advanced IGBT power switching technology	Advanced sensorless vector control, providing a powerful starting torque at low frequency with high performance operation at the highest efficiency.
	Output frequency range is 0-650Hz	
	Power range: 200V 0.4~15kW (0.5HP~20HP) 400V 0.75~18.5kW (1HP~25HP)	
H/W Function	The latest generation of IGBT power module	New generation of IPM/ PIM power module can reach higher efficiency of switching and compact design of inverters.
	With 7-segment *5 display panel	From this information, users can be easy to understand the usage state of inverters.
	Standard built-in VR knob	Directly frequency setting and simple to adjust speed
	Built-in EMC filter in compliance with IEC/ EN 61800-3 & 61800-5-1	Lower electromagnetic interference effectively
	Fan control (set by parameter)	Fan control is based on the ambient temperature of key components to lower noise and avoid unnecessary energy wasted.
S/W Function	Soft-PWM modulation	Reduce audible motor noise at low carrier frequency
	Integrated safety stop and fire mode functions	Provide advanced application functions under the circumstance of emergency or fire.
	Auto carrier frequency switching	Built-in sensors detection on operation temperature to avoid the probability of inverter tripping in too high temperature.
	Built-in PID controller	Provide constant control requirements of frequency, pressure, flow, air volume in applications, such as HVAC
	Built-in PLC function	Simple process control to save the cost of external PLC
Expansion Flexibility	Built-in Modbus Communication (RS485)	Fast parameters copying to reduce time of installation, maintenance and replacement.
	PC-software/ Copy unit	
Quality	External cooling heatsink	Reduce the possibility of unknown objects entering to avoid damaging components and improve product reliability.

MODEL IDENTIFICATION

E510	2	P5		H	1	F
	Input Voltage	Horse Power		Type	Power Supply	Noise Filter
E510 series	2: 200V class	P5: 0.5 HP	08: 7.5 HP	H: Standard (IP20)	1: Single-phase	Blank: None F: Built-in
	4: 400V class	01: 1 HP	10: 10 HP		3: Three-phase	
		02: 2 HP	15: 15 HP		Blank: Single-/	
		03: 3 HP	20: 20 HP		Three-phase	
		05: 5 HP	25: 25 HP			

CAPACITY RANGE

Power Rating	0.4kW 0.5HP	0.75kW 1HP	1.5kW 2HP	2.2kW 3HP	3.7kW 5HP	5.5kW 7.5HP	7.5kW 10HP	11kW 15HP	15kW 20HP	18.5kW 25HP
E510	200V 1-phase (with filter)									
	200V 1-/ 3-phase									
		200V	n/a	200V 3-phase						
	400V 3-phase									

APPLICATIONS

- Textiles
- Woodworking
- Small Handling Machine
- Simple Metal Processing
- Machine Tools
- Packaging & Labeling
- Food processing
- Fans & Pumps
- HVAC



WIRING DIAGRAM

Single-phase/ Three-phase

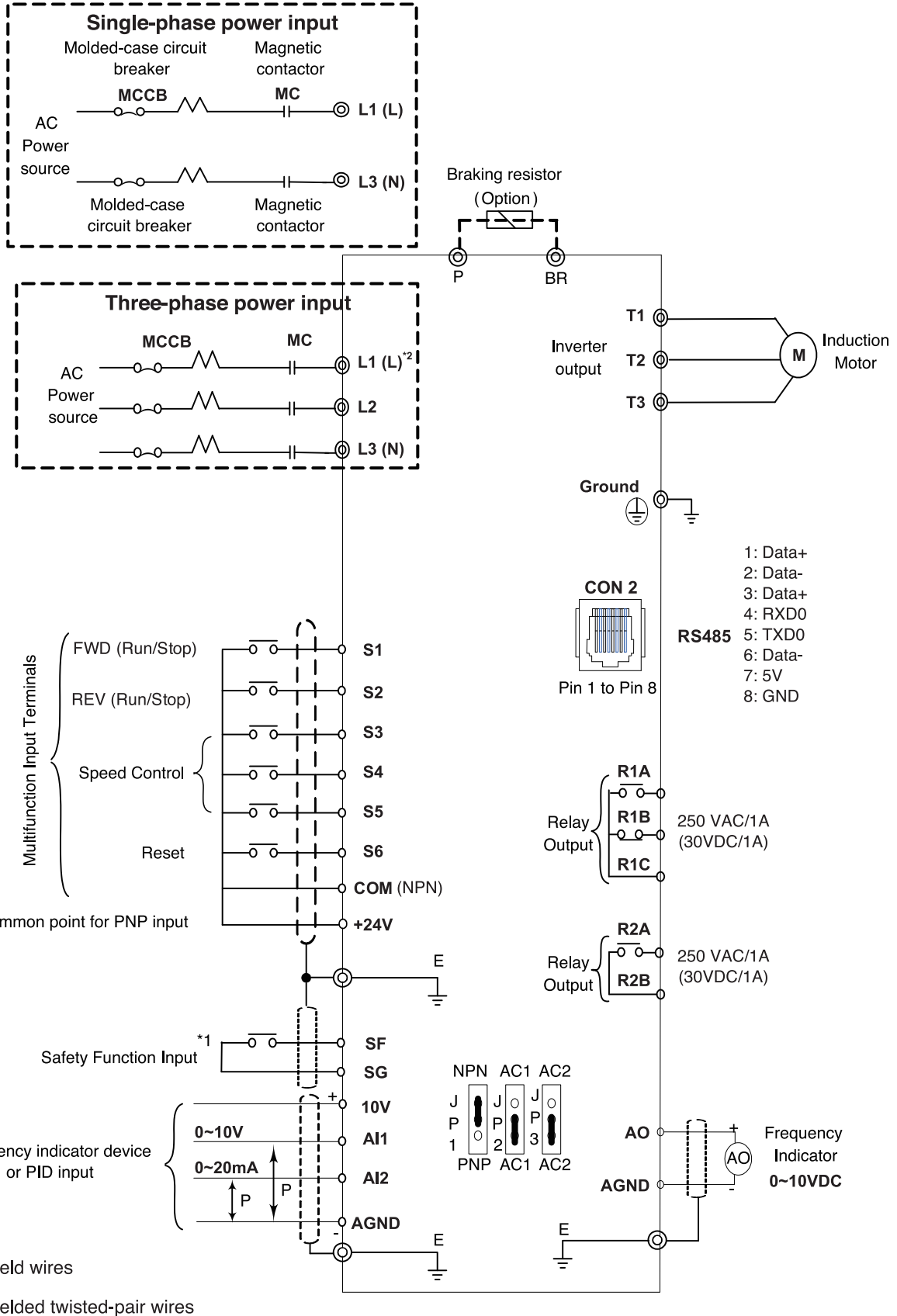

*1: When using function of safe input, the terminal SF-SG requires short circuit and inverter will stop output at once.

*2: Power input terminal is L1, L2, L3 in 200V 7.5HP~20HP/ 400V 7.5HP~25HP.

GENERAL SPECIFICATIONS

Item		E510
Control Mode		V/F Control, Vector Control
Frequency	Output Frequency	0.01~650.00Hz
	Starting Torque	150%/1Hz(Vector)
	Speed Control Range	1:50
	Setting Resolution	Digital input: 0.01Hz Analog input:0.06Hz/60Hz
	Setting	Keypad: Set directly with▲▼ keys or the VR on the keypad External Input Terminlas: AI1(0/2~10V), AI2(0/4~20mA)input Multifunction input up/down function(Group3) Setting frequency by communication method.
	Frequency Limit	Lower and upper frequency limits 3 jump frequency settings.
Run	Operation Set	Keypad run, stop button
		External terminals: Multi- operation-mode2 / 3 wire selection Jog operation
		Run signal by communication method.
Main Control Features	V/F Curve Setting	18 fixed curves and one customized curve
	Carrier Frequency	1~16KHz
	Acceleration and Deceleration Control	2 sections of acceleration/ deceleration time setting (0.1~3600.0 Sec.) 4 sections of S curve setting
	Multifunction Input	29 functions (refer to group 3 in the manual)
	Multifunction Output	20 functions (r refer to group 3 in the manual)
	Multifunction Analog Output	5 functions (refer to n group 3 in the manual)
	Main Features	Overload Detection,16 preset speeds, Auto-run, Acc/Dec Switch, Main/Alt Run Command Select, Main/Alt Frequency Command Select ,PID control, Torque Compensation, V/F Start Frequency, Slip Compensation, Fault Reset.
Display	LED	Display: parameter / parameter value / frequency / line speed / DC voltage / output voltage / output current / PID feedback / input and output terminal status / Heat sink temperature / Program version / Fault Log.
	LED Status Indicator	Run / Stop / Forward / Reverse ,and etc.
Protective Functions	Overload Protection	The relays to protect the motor and the inverter. (150%/1min)
	Over Voltage	200V class: >410V , 400V class: >820V
	Under Voltage	200V class: <190V , 400V class: <380V
	Momentary Power Loss Restart	Inverter auto-restart after a momentary power loss.
	Stall Prevention	Stall prevention for Acceleration/ Deceleration/ Operation.
	Short-circuit Output Terminal	Electronic Circuit Protection
	Grounding Fault	Electronic Circuit Protection
	Other Protection Functions	Protection for overheating of heat sink, the carrier frequency decreasing with the temperature function, fault output, reverse prohibit, prohibit for direct start after power up and error recovery ,parameter lock up
All frames include brake transistor		
Communication control		Standard built-in RS485 communication (Modbus), One to one or One to many control.
Environment	Operating temperature	-10~50°C (without dustproof cover/ paster) -10~40°C (with dustproof cover/ paster)
	Storage temperature	-20~60°C
	Humidity	95% RH or less (no condensation)(Compliance with IEC 60068 - 2-78)
	Shock	1.0G, in compliance with IEC 60068-2-6
	Enclosure	IP20

BASIC SPECIFICATIONS

Model	200V Class: Single-phase			
	E510-□□□- H1F			
	2P5	201	202	203
Horse Power (HP)	0.5	1	2	3
Suitable Motor Capacity (KW)	0.4	0.75	1.5	2.2
Rated Output Current (A)	3.1	4.5	7.5	10.5
Rated Capacity (KVA)	1.2	1.7	2.9	4.0
Input Voltage Range(V)	Single-phase 200~240V, 50/60HZ			
Allowable Voltage Fluctuation	-15%~+10%			
Output Voltage Range(V)	Three-phase 0~240V			
Input Current (A)	8.5	12	16	23.9
Inverter Net Weight (KG)	1.65	1.65	2.5	2.5
Allowable Momentary Power Loss Time (Sec.)	2.0		2.0	
Enclosure	IP20			
Frame Size	1		2	

Model	200V Class: Single-/Three-phase			
	E510-□□□- H			
	2P5	201	202	203
Horse Power (HP)	0.5	1	2	3
Suitable Motor Capacity (KW)	0.4	0.75	1.5	2.2
Rated Output Current (A)	3.1	4.5	7.5	10.5
Rated Capacity (KVA)	1.2	1.7	2.9	4.0
Input Voltage Range(V)	Single-/Three-phase 200~240V, 50/60HZ			
Allowable Voltage Fluctuation	-15%~+10%			
Output Voltage Range(V)	Three-phase 0~240V			
Input Current (A)	8.5/4.5	12/6.5	16/11	23.9/12.5
Inverter Net Weight (KG)	1.65	1.65	2.5	2.5
Allowable Momentary Power Loss Time (Sec.)	2.0		2.0	
Enclosure	IP20			
Frame Size	1		2	

Model	200V Class: Three-phase					
	E510-□□□- H3					
	202	205	208	210	215	220
Horse Power (HP)	2	5	7.5	10	15	20
Suitable Motor Capacity (KW)	1.5	3.7	5.5	7.5	11	15
Rated Output Current (A)	7.5	17.5	26	35	48	64
Rated Capacity (KVA)	2.9	6.7	9.9	13.3	20.6	27.4
Input Voltage Range(V)	Three-phase 200~240V, 50/60HZ					
Allowable Voltage Fluctuation	-15%~+10%					
Output Voltage Range(V)	Three-phase 200~240V					
Input Current (A)	11	20.5	33	42	57	70
Inverter Net Weight (KG)	1.65	2.5	6.5	6.5	10.1	10.4
Allowable Momentary Power Loss Time (Sec.)	2.0	2.0	2.0		2.0	
Enclosure	IP20					
Frame Size	1	2	3		4	

Model	400V Class: Three-phase									
	E510-□□□- H3 (F)									
	401	402	403	405	408	410	415	420	425	
Horse Power (HP)	1	2	3	5	7.5	10	15	20	25	
Suitable Motor Capacity (KW)	0.75	1.5	2.2	3.7	5.5	7.5	11	15	18.5	
Rated Output Current (A)	2.3	3.8	5.2	8.8	13.0	17.5	24	32	40	
Rated Capacity (KVA)	1.7	2.9	4.0	6.7	9.9	13.3	19.1	27.4	34	
Input Voltage Range(V)	Three-phase 380~480V, 50/60HZ									
Allowable Voltage Fluctuation	-15%~+10%									
Output Voltage Range(V)	Three-phase 0~480V									
Input Current (A)	4.2	5.6	7.3	11.6	17	23	31	38	48	
Inverter Net Weight (KG)	1.7	1.7	2.5	2.5	6.7	6.7	6.7	10.5	10.5	
Allowable Momentary Power Loss Time (Sec.)	2.0		2.0		2.0			2.0		
Enclosure	IP20									
Frame Size	1		2		3			4		

DIMENSIONS

Unit: mm (inch)

Frame	W	W1	W2	H	H1	H2	D	D1	D2	E	Q1	Q2
Frame 1	90.6 (3.57)	81 (3.19)	81 (3.19)	163.6 (6.44)	153 (6.02)	173.5 (6.84)	146.8 (5.78)	141 (5.55)	-	48 (1.89)	4.3 (0.17)	4.3 (0.17)
Frame 2	128.7 (5.07)	118 (4.65)	118 (4.65)	187.6 (7.39)	177.6 (6.99)	197.5 (7.78)	147.8 (5.82)	133.8 (5.27)	141.8 (5.58)	48.2 (1.9)	4.5 (0.18)	4.5 (0.18)
Frame 3	186.9 (7.36)	176 (6.92)	175 (6.89)	260.9 (10.27)	249.8 (9.83)	273 (10.75)	195 (7.68)	184 (7.24)	189 (7.44)	84.7 (3.33)	4.5 (0.18)	4.5 (0.18)
Frame 4	224.6 (8.84)	207 (8.15)	207 (8.15)	321.6 (12.66)	303.5 (11.95)	330.9 (13.03)	198.3 (7.8)	187.5 (7.38)	192.5 (7.58)	94 (3.7)	4.5 (0.18)	4.5 (0.18)

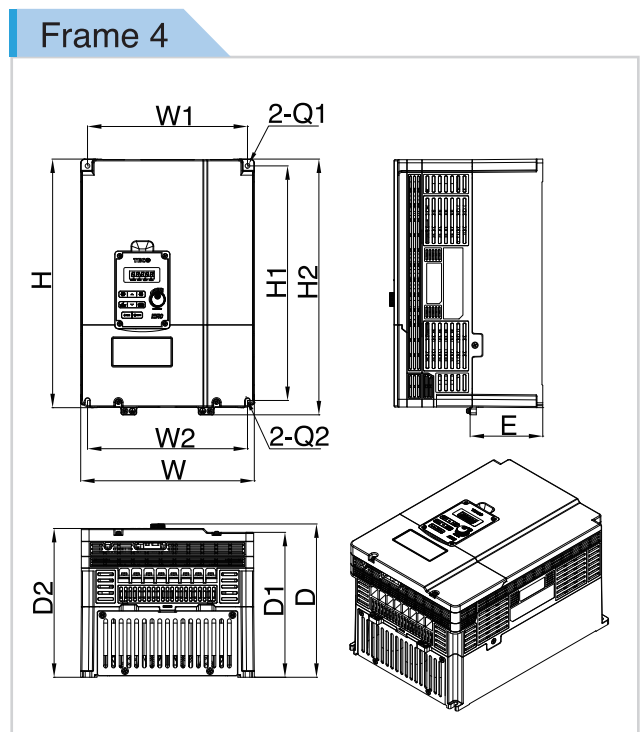
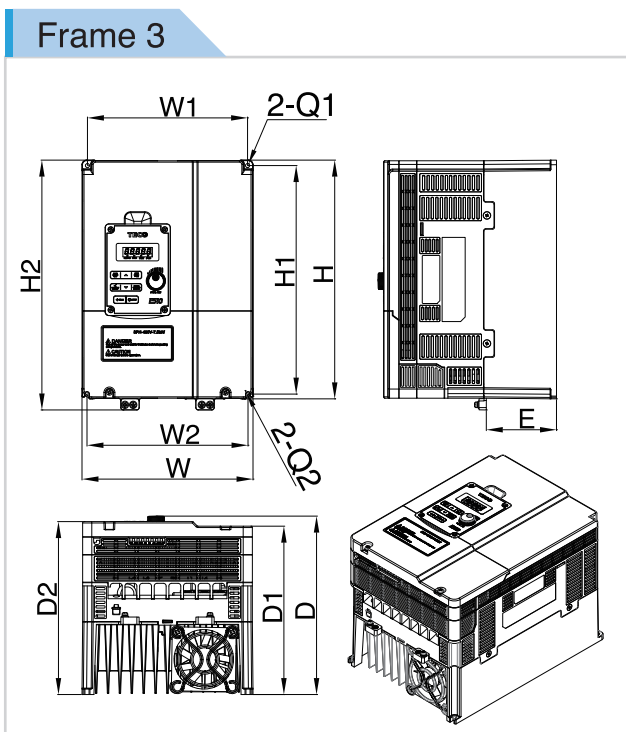
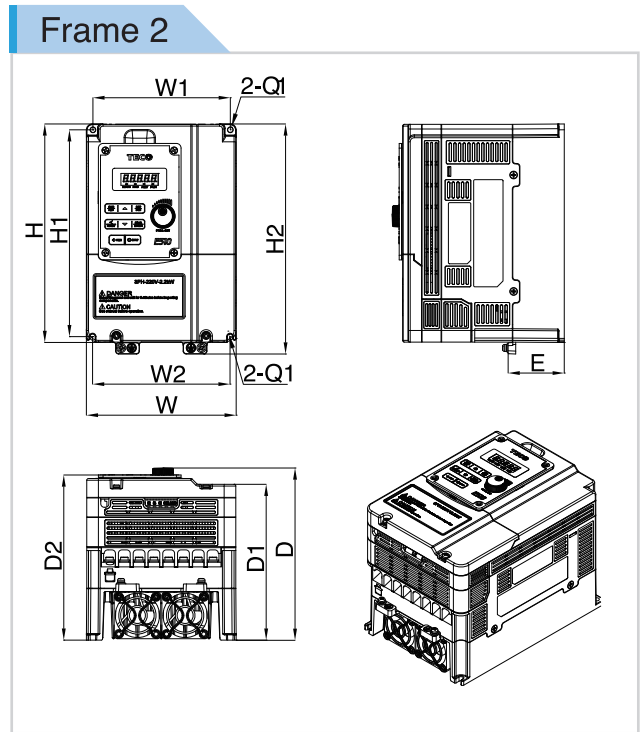
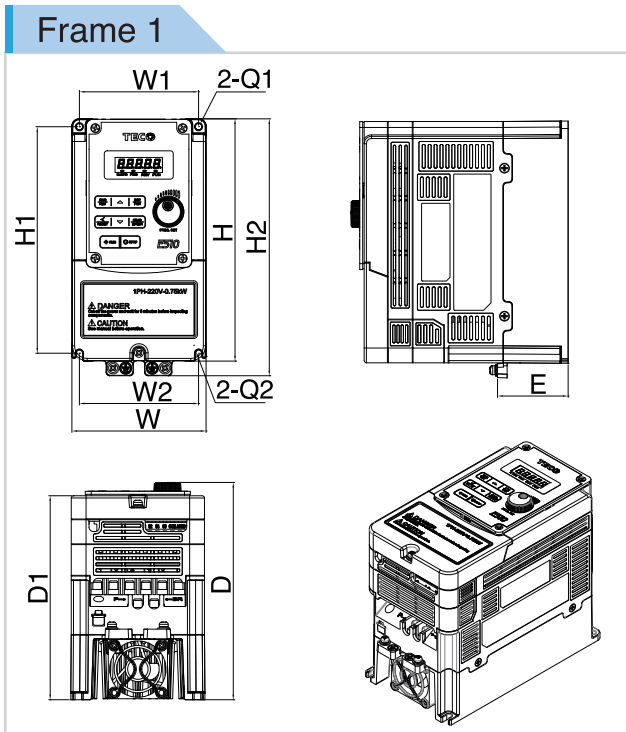



Distributor



TECO ELECTRIC & MACHINERY CO., LTD.

10F, No. 3-1, Yuan Cyu St., Nan-Kang District, Taipei 115, Taiwan

TEL : 886-2-6615-9111Ext.1725

FAX : 886-2-6615-1033

<http://globalsa.teco.com.tw>

Specifications covered in this brochure may be subject to change without notice.

GJ-62-03 2013-04-15